

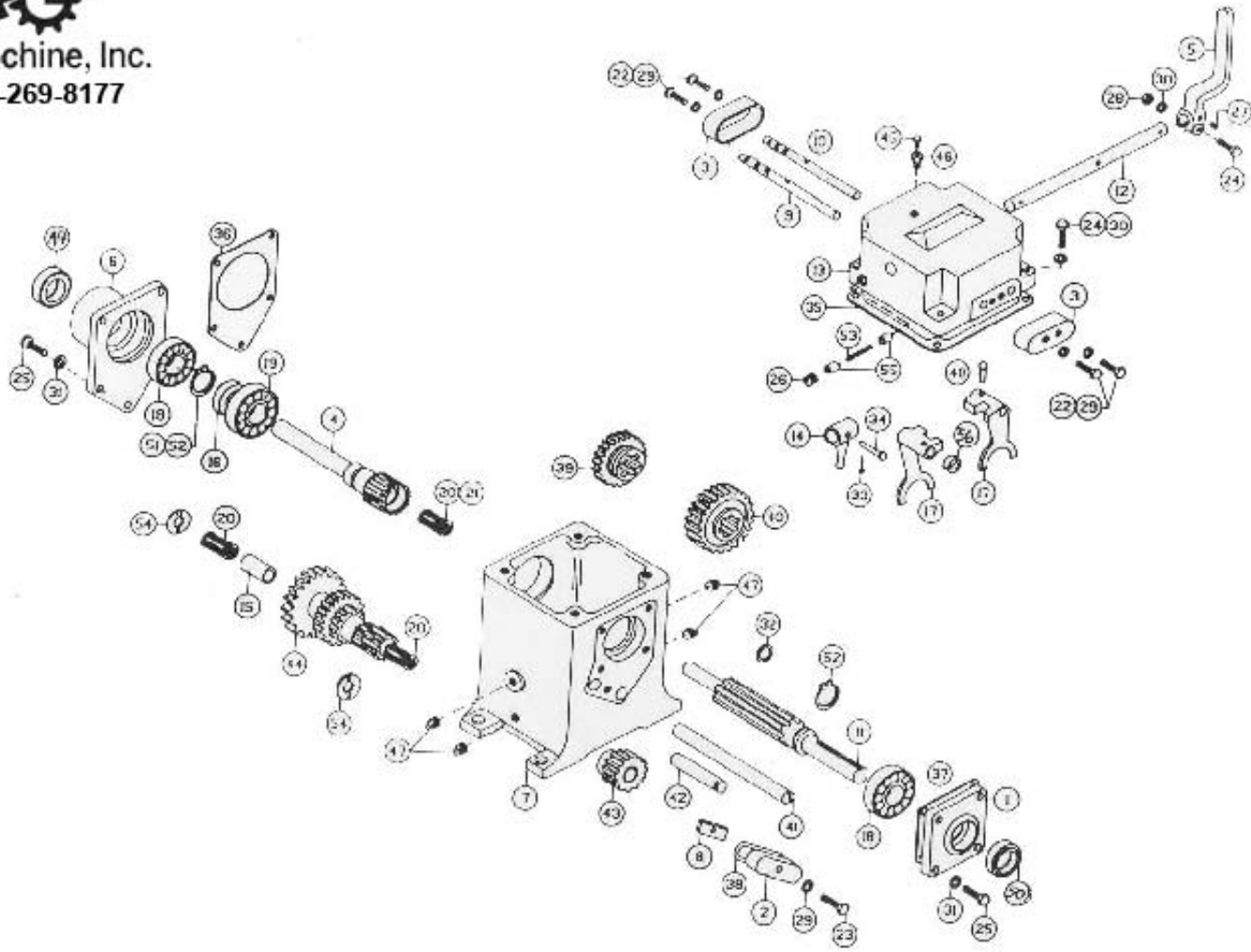

MODEL 1-MS



MODEL 1-MS
PART NO. R150011
HP RATING 30 @ 1,250 RPM
SERIES 1-M
SPEEDS 3 Forward / 1 Rev.

Ratios
 1.000:1
 1.852:1
 3.125:1
 3.745:1 Rev.

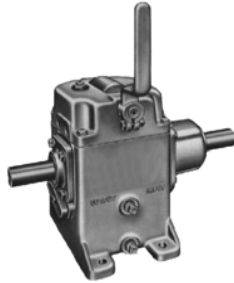

<i>Item</i>	<i>Part No</i>	<i>Description</i>	<i>Qty</i>	<i>Item</i>	<i>Part No</i>	<i>Description</i>	<i>Qty</i>
1	316047	Bearing Ret.	1	29	418154	Washer	5
2	328039	Cap-Shift Head	1	30	418163	Washer-Flat	5
3	328040	Cap-Shift Shaft	2	31	418184	Washer-Flat	9
4	334041	Gear-Main Drive	1	32	418506	Spacer	1
5	336002	Handle	1	33	424001	Cotter Pin	1
6	352013	Brg. Housing	1	34	424200	Clevis Pin	1
7	338035	Housing	1	35	442023	Gasket-Cover	1
8	352016	Ret. Shaft	2	36	442027	Gasket-Bearing	1
9	356920	Shift-Shaft	1	37	442028	Gasket-Bearing	1
10	356921	Shift-Shaft	1	38	442082	Gasket-Cover	1
11	356934	Main Shaft	1	39	444014	Gear-Int. Sliding	1
12	355048	Shift-Shaft (Mathey)	1	40	444015	Gear-Sliding	1
13	358022	Shifter-Head	1	41	444016	Shaft-Gear	1
14	358024	Shifter-Dog	1	42	444017	Shaft-Gear	1
15	362044	Spacer Bearing	1	43	444018	Gear-Idler	1
16	362063	Spacer Bearing	1	44	444019	Cluster Gear	1
17	370013	Yoke-Shifter	2	45	456008	Relief Fitting	1
18	402013	Bearing-Ball	2	46	468002	Reducer	1
19	402014	Bearing Ball	1	47	468011	Pipe Plug	1
20	402020	Bearing-Roller	2	48	480002	Rivet	2
21	402034	Bearing-Roller	1	49	486019	Oil Seal	1
22	414040	Cap Screw	4	50	486068	Oil Seal	1
23	414039	Cap Screw	1	51	490014	Snap Ring	1
24	414139	Cap Screw	1	52	490015	Snap Ring	2
25	414281	Cap Screw	9	53	494012	Spring Lock	1
26	414971	Screw-Poppet	1	54	518002	Thrust Washer	2
27	416057	Set Screw	1	55	530044	Poppet	2
28	418022	Nut	1	56	362192	Spacer	1

Series 1M Transmissions



Models 1MS and 1MCS

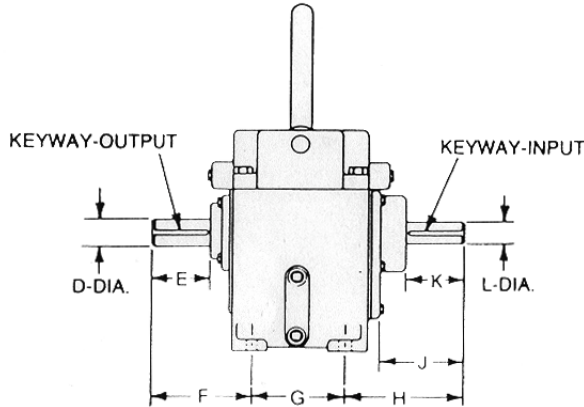
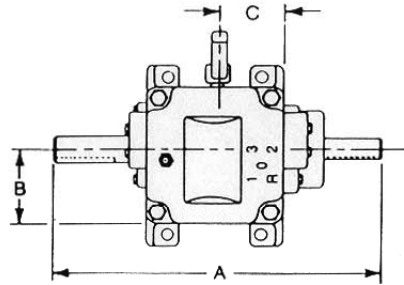

SPECIFICATIONS							
Model No.	Rating at 1200 RPM	Input to Output Ratios				Approx. Weight	
		Low	2nd	High	Reverse	Iron	Alum. Alloy
1M	30 HP	1:320	1:540	1:1	1:267	66 lbs.	36 lbs.

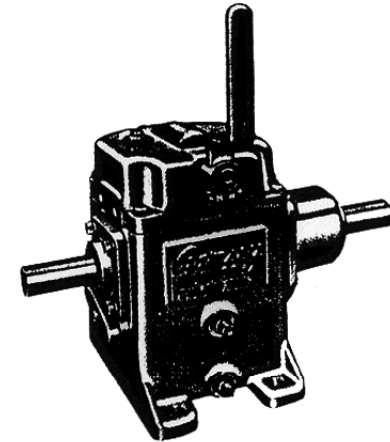
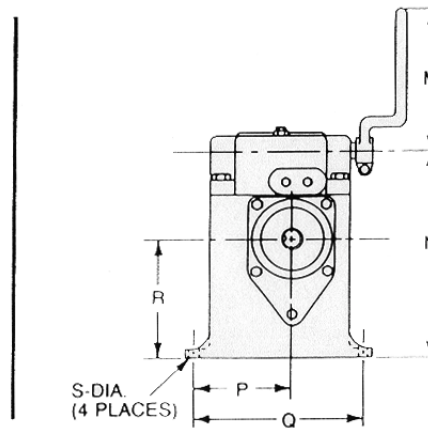

LETTERED DIMENSIONS																			
Model	A Inches MM	B Inches MM	C Inches MM	D Inches MM	E Inches MM	F Inches MM	G Inches MM	H Inches MM	J Inches MM	K Inches MM	L Inches MM	M Inches MM	N Inches MM	P Inches MM	Q Inches MM	R Inches MM	S(DIA) Inches MM	Keyway Input	Keyway Output
1MS	16.12 409.6	3.00 76.2	3.12 79.4	1.25 31.7	2.62 66.7	4.62 117.5	4.12 104.8	7.37 187.3	5.81 147.6	3.00 76.2	1.37 34.9	6.37 161.9	9.87 250.8	4.56 115.9	7.87 200.0	5.69 144.4	.53 13.5	.31 (W) .16 (D) 2.75 (L)	.25 (W) .12 (D) 2.44 (L)
1MCS	16.19 411.1	3.00 76.2	3.12 79.4	1.12 28.6	2.81 71.4	4.81 122.8	4.12 107.8	7.25 184.1	5.69 144.4	2.69 68.2	1.00 25.4	6.25 158.7	9.87 250.8	4.56 115.9	7.87 200.0	5.69 144.4	.53 13.5	.25 (W) .12 (D) 2.50 (L)	.25 (W) .12 (D) 2.62 (L)